



Water & Sewage  
Pumping and  
Treatment Engineers

*The Pump People.*

**Pump-in-a-Box**

Amos Pumps (UK) Ltd  
Wendron, Helston,  
Cornwall. TR13 0PY  
Tel: 01326-573341  
Email: info@amospumps.com  
Web site: amospumps.com

\*\*\*\*\***Technical Data Sheet**

**General Characteristics**

The Pump-in-a-Box is designed for home or industrial use with automatic operation having many commercial uses as well as domestic. Being designed to be free standing it eliminates the need for costly excavations thus making it suitable both for the handy D.I.Y. builder or to be used in temporary situations.

The Box has part cut holes for easy access for plumbing fittings making it ideal for fixing to washing machines or dishwashers in basements or sinks in utility rooms below drain height or for taking the dirty water from a shower.

The technopolymer container holds 30 litres, opening is easy by removing the clips on the lid which is sealed with a soft rubber gasket to stop any odours being released.

Operating temperature range and full technical details are available.



| <b>Hydraulic Data -</b> |     |     |     |     |     |
|-------------------------|-----|-----|-----|-----|-----|
| litres per minute       | 0   | 40  | 80  | 100 | 120 |
| metres head             | 6.9 | 5.3 | 3.2 | 2   | 1   |

Total weight: 9.2 Kg.

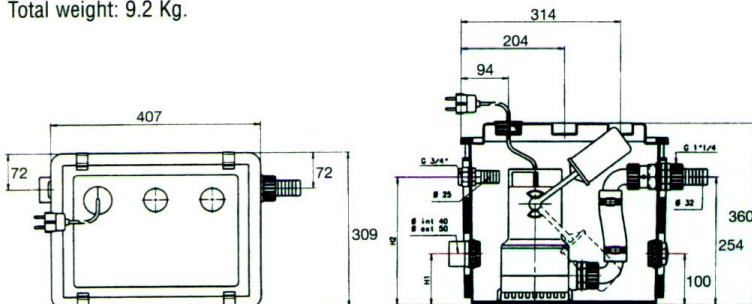

**Pump Technical Specification**

Pump - 240/220v, 1ph, 50Hz 0.3 hp motor with floatswitch connected, integral capacitor, supplied with 5 metres of cable with moulded 13 amp plug.  
Solids handling capacity of 10 mm diameter soft solids. Not sewage.

Manufacturers reserve the right to change specifications without prior notice

Leaflet P-Box—Mar 10